

Please read this instruction manual carefully prior to installation. Keep this manual readily available for future reference.



ATTENTION

1. Upon installation, please ensure that your surrounding environment is clean, as it may affect it's precision.
2. We shall not be held liable and shall not accept any liability, obligation or responsibility whatsoever for any damage on the item during the course of assembly and/or disassembly.
3. Please seek professional advice or assistance if you are unclear of the instructions or have any doubts regarding the procedures.
4. This cylinder block kit is compatible for **HONDA RS150R & SONIC150**.

1 PARTS INCLUDED

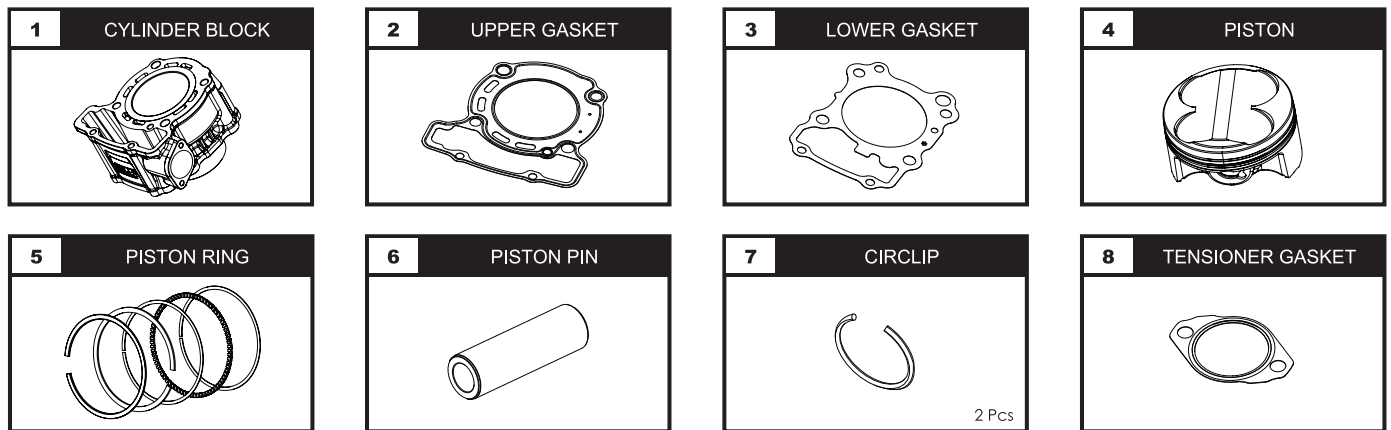

NOTE Please ensure contents match the above diagrams. If there are missing or mismatched parts, kindly contact the dealer or seller where the purchase was made.

2 DISASSEMBLING THE TIMING CHAIN

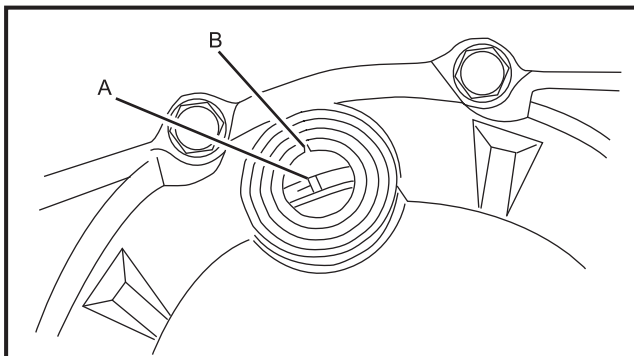

1. Make sure the mark (A) on the flywheel is aligned with mark (B) on the engine body.

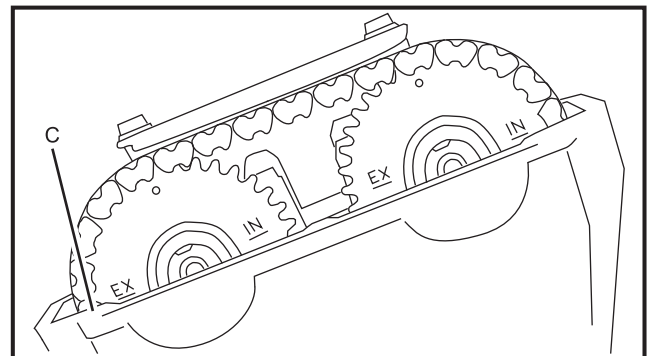

2. Align both of the timing gear's mark 'EX' & 'IN' to be parallel with the mark 'C'

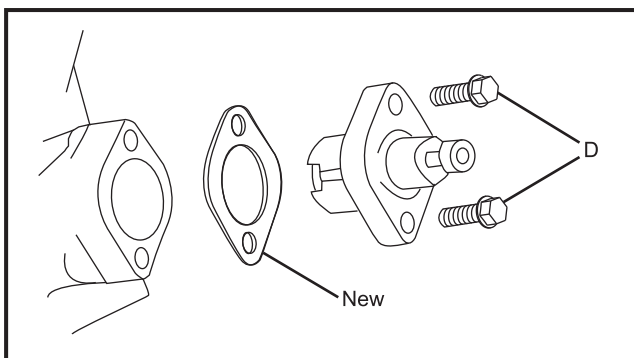

3. Unscrew the bolts marked 'D' to release the timing chain tensioner.

NOTE Upon reassembling, it is recommended to replace the tensioner gasket.

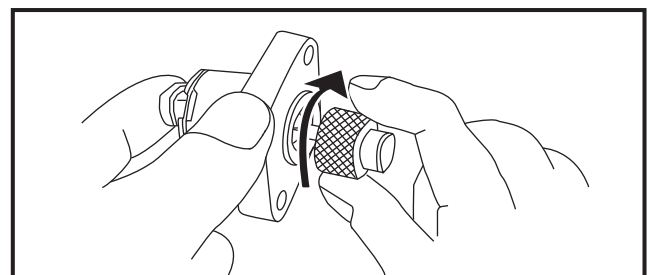

- Installing the cam chain tensioner.

NOTE Rewind the cam chain tensioner prior to installation. While holding down the back of the cam chain tensioner as per figure above, use a flat head screwdriver to rewind the spiral spring by turning clockwise.

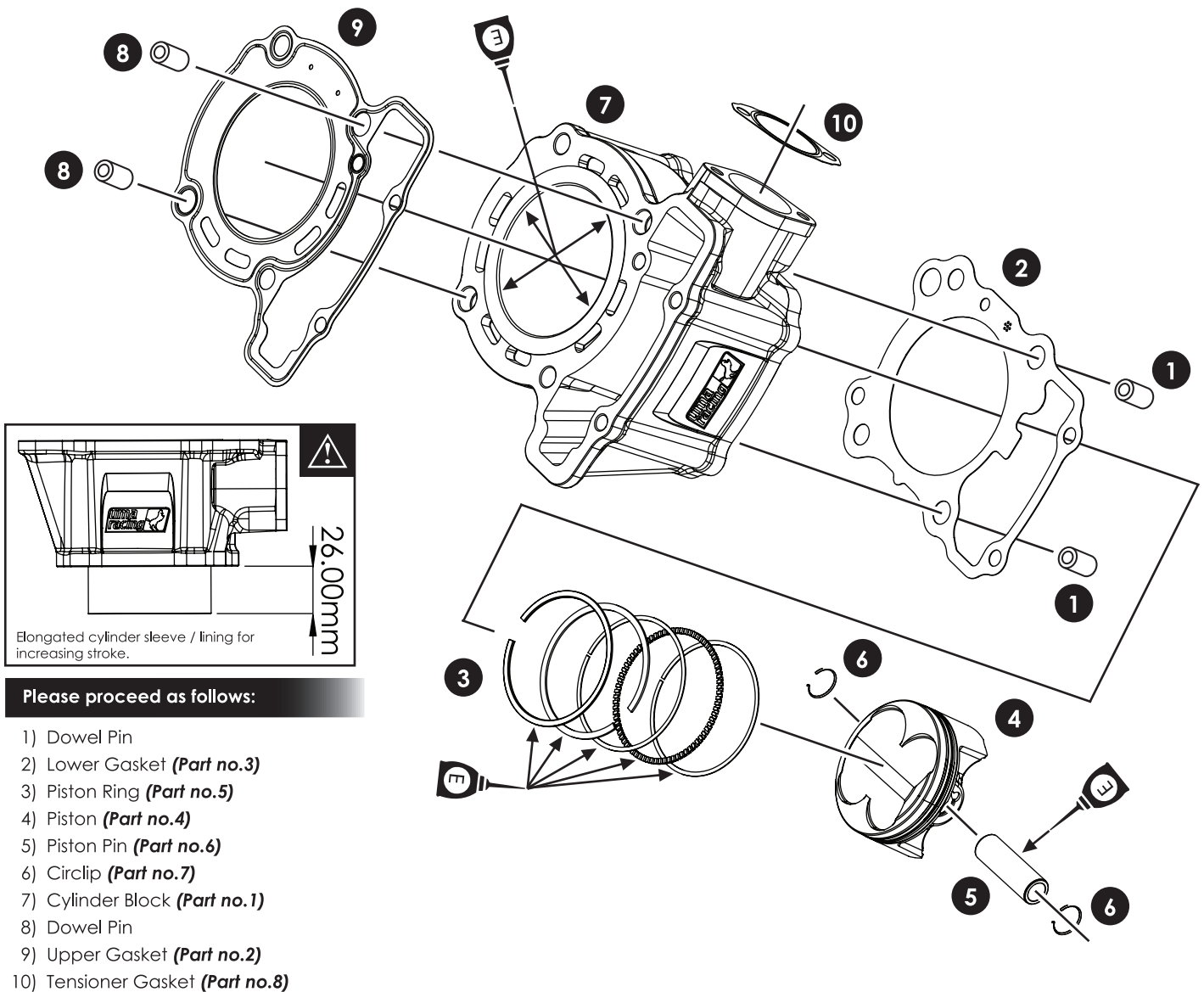

⚠ Remove the entire top end of the engine in order to facilitate the replacement of the cylinder block.

⚠ Before installing the cylinder block, apply lubricant or engine oil on the cylinder sleeve to avoid scratching or damaging the cylinder lining or piston.

NOTE Disassemble the engine according to the steps above. The installation of the cylinder block and piston should be performed in reverse sequence.

🔧 To apply / smear with lubricant or engine oil.

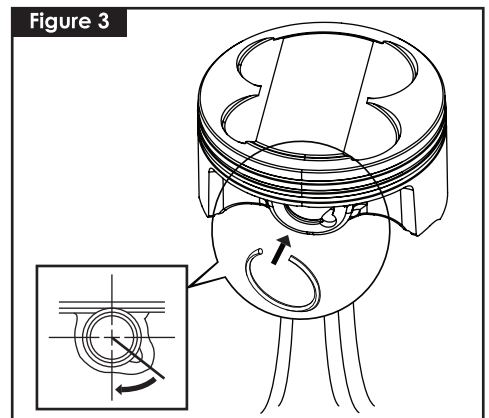
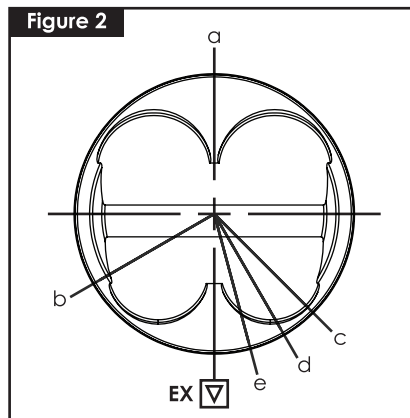
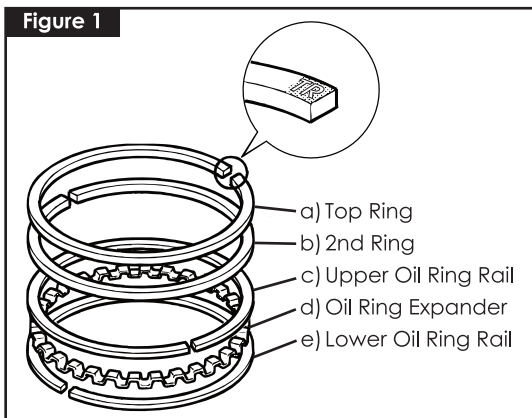

⚠ The marks on the piston rings must be installed facing up as shown in Figure 1. Piston ring compression gaps must be positioned as per Figure 2.

NOTE Upon installation, align the mark (EX) on the top of the piston with the exhaust port.

NOTE Be careful not to lose the circlip during installation. (Figure 3)