

Thank you for purchasing this product. Please read the instruction carefully for details prior to installation.



ATTENTION

1. Prior to installation please ensure the environment or workplace is clean as it may affect its precision.
2. We shall not be held liable and shall not accept any liability, obligation or responsibility whatsoever for any damage on the item during assembly and disassembly.
3. Please seek professional assistance or advice if you are unclear of the instructions and have any doubts.

1 PARTS INCLUDED

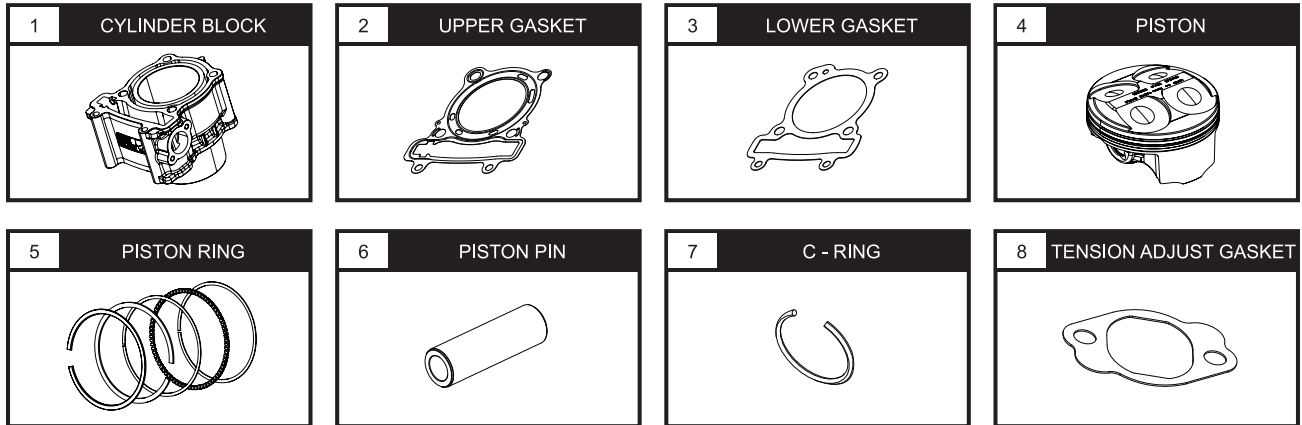

NOTE Please ensure contents matches the above diagrams. If there are missing or mismatched parts, please contact the dealer or seller where you bought from.

2 DISASSEMBLING TIMING CHAIN

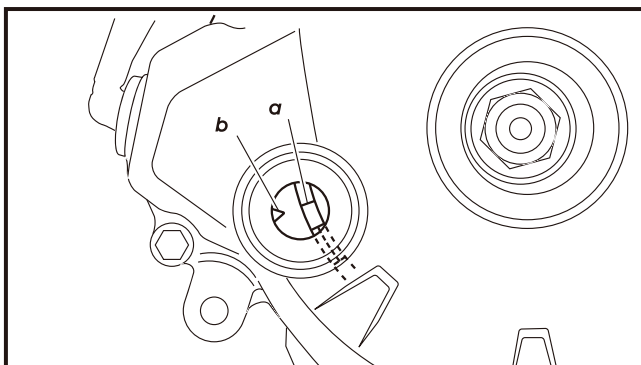

1. Make sure the mark (a) on the flywheel is aligned with mark (b) on the engine body.

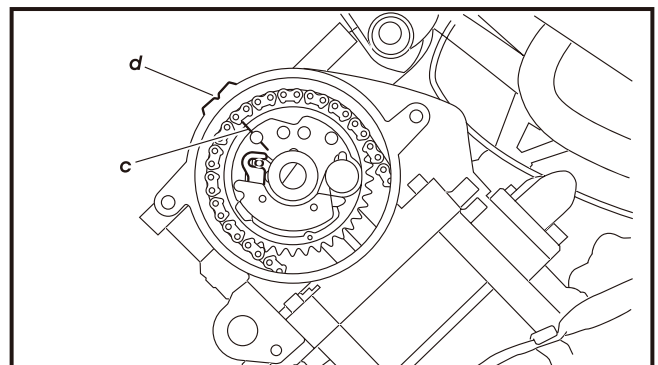

2. Align mark (c) on the camshaft with mark (d) on the cylinder head.

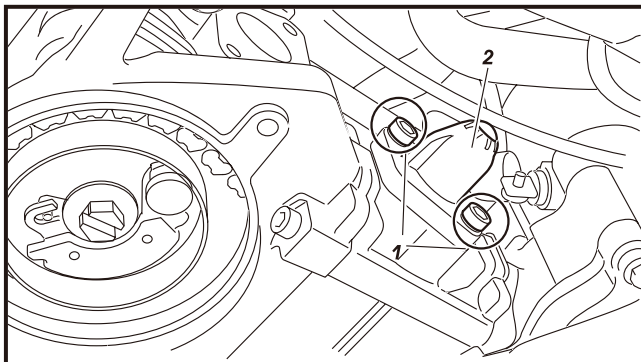

2. Release the two screws marked (1) on above diagram and then take the chain tension regulator out (2).

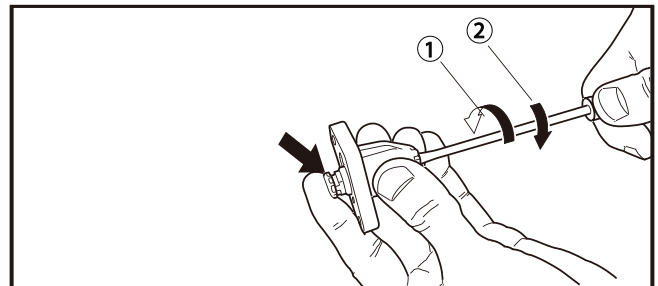

• Install chain tension regulator.

NOTE Use a flathead screwdriver on the back side of the chain tension regulator. Turn chain tension regulator clockwise to fix the spring inside the regulator.

NOTE To smear with engine oil.

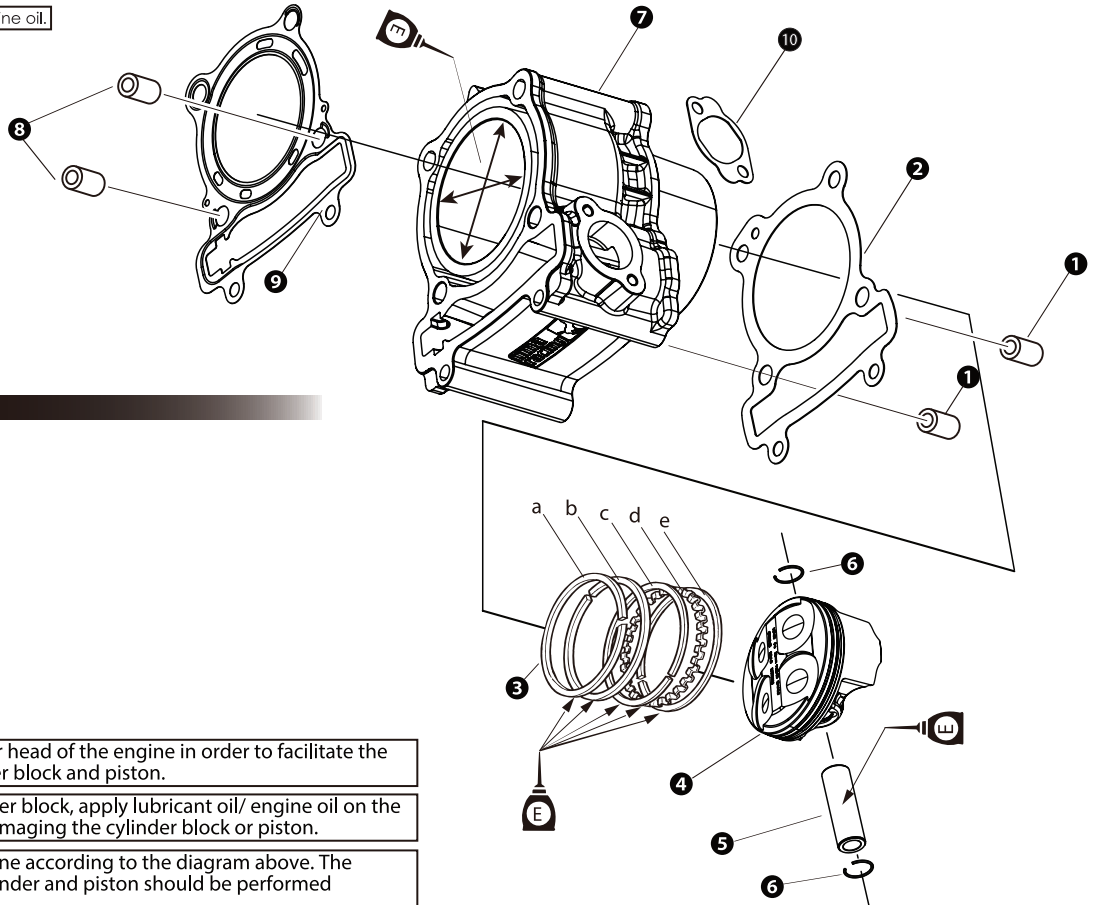

Please proceed as following.

- ① Dowel Pin
- ② Lower Cylinder Gasket
- ③ Piston Ring
- ④ Piston
- ⑤ Piston Pin
- ⑥ C - Ring
- ⑦ Cylinder Block
- ⑧ Dowel Pin
- ⑨ Upper Cylinder Gasket
- ⑩ Tension Adjust Gasket

⚠ Remove the entire cylinder head of the engine in order to facilitate the replacement of the cylinder block and piston.

⚠ Before installing the cylinder block, apply lubricant oil/ engine oil on the cylinder sleeve to avoid damaging the cylinder block or piston.

NOTE Disassemble the engine according to the diagram above. The installation of the cylinder and piston should be performed in reverse sequence.

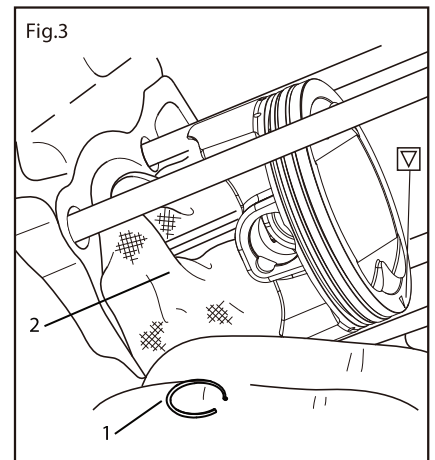
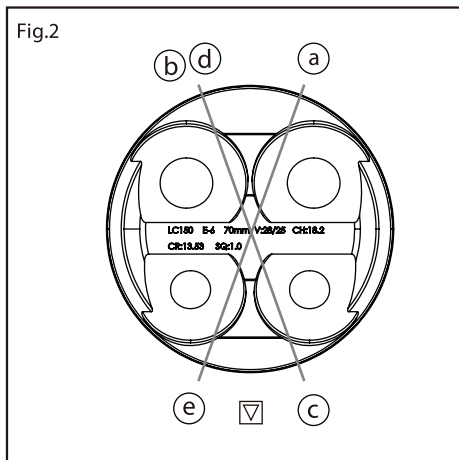
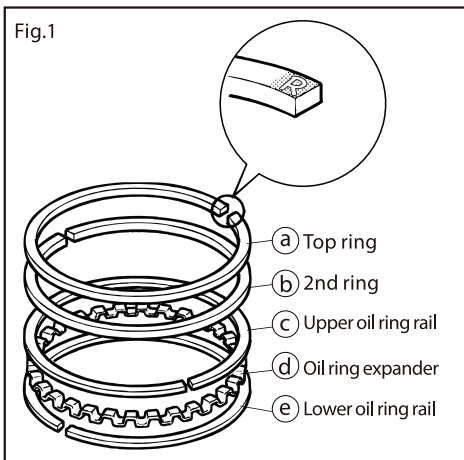

⚠ The mark on the ring must be faced up when install(As Fig.1 shows). Also the ring open side must be facing the position as Fig.2 shows.

NOTE The mark on the top of piston must be aligned with exhaust port when install.

NOTE Be careful not to lose C clip when install.

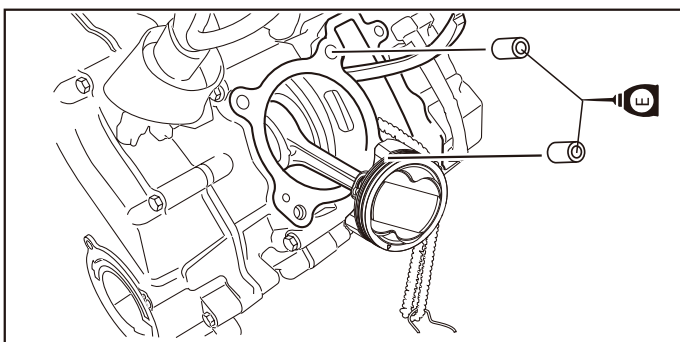

1.Install rod end into cylinder.

NOTE You may need to use lubricating oil when installation.

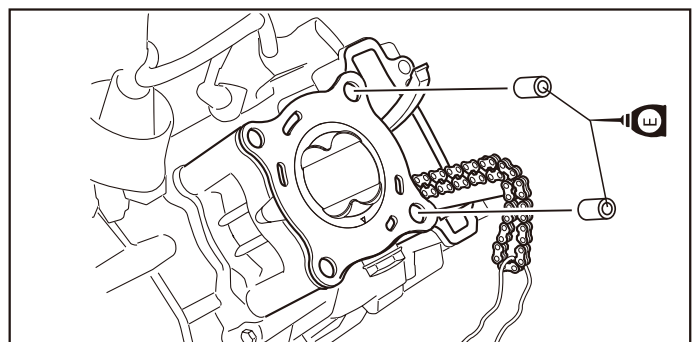

2.Install gasket alignment pin on cylinder.